

© COPYRIGHT 1968 BY AMP INCORPORATED, HARRISBURG, PA.
 ALL INTERNATIONAL RIGHTS RESERVED. AMP INCORPORATED PRODUCTS
 COVERED BY U. S. AND FOREIGN PATENTS AND/OR PATENTS PENDING.

REVISIONS						
P	F	ZONE	LTR	DESCRIPTION	DATE	APPROVED
/	✓		S	REDWN; RMD FROM 61115, M-5591	11-30-79	MSF/J.H.
/	✓		T	REV. NOTE 1, ADDED NOTE 3 M-6033	10-1-80	MSF/J.H.
/	✓		U	ADDED 1--0 PER M-6165	12-2-80	MSF/J.H.
/	✓		V	REV. FINISH -7 PER M-6255	1-28-81	MSF/J.H.
/	✓		W	ADDED POINT OF MEASUREMENT, M-7310	4/17/83	DAS/J.H.
/	✓		X	ECN M-7426	6-16-83	JAMES J.M.
/	✓		Y	REV PER ECN AG-25	10-11-83	TEB K.W.
/	✓		Y	RESTORATION	4-23-85	MC H.S.
/	✓		Z	OBS. 1-1, 1-5, 1-6 PER ECN CM 473	4/4/86	IB/RS
/	✓		AA	OBSOLETE 1-4 PER ECN CM-761	4/20/87	PHS/IB
/	✓		AB	OBS 1--0 PER EC-0730-0127-96	6-19-97	JH/RS

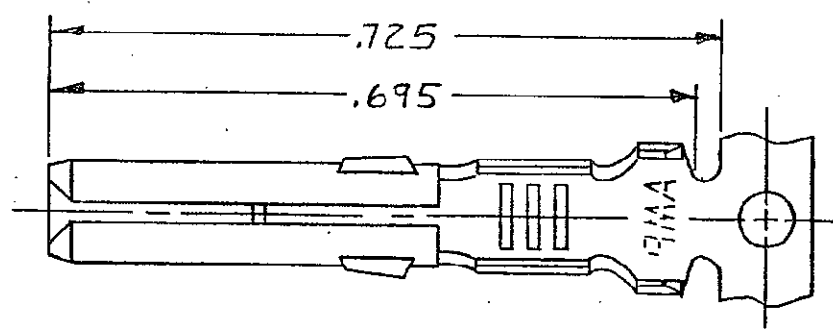

POINT OF MEASUREMENT
INSIDE OF RECEPTACLE

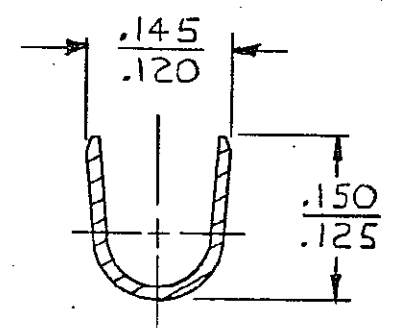
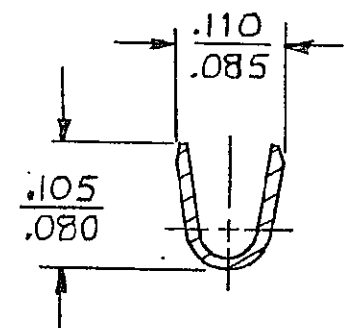
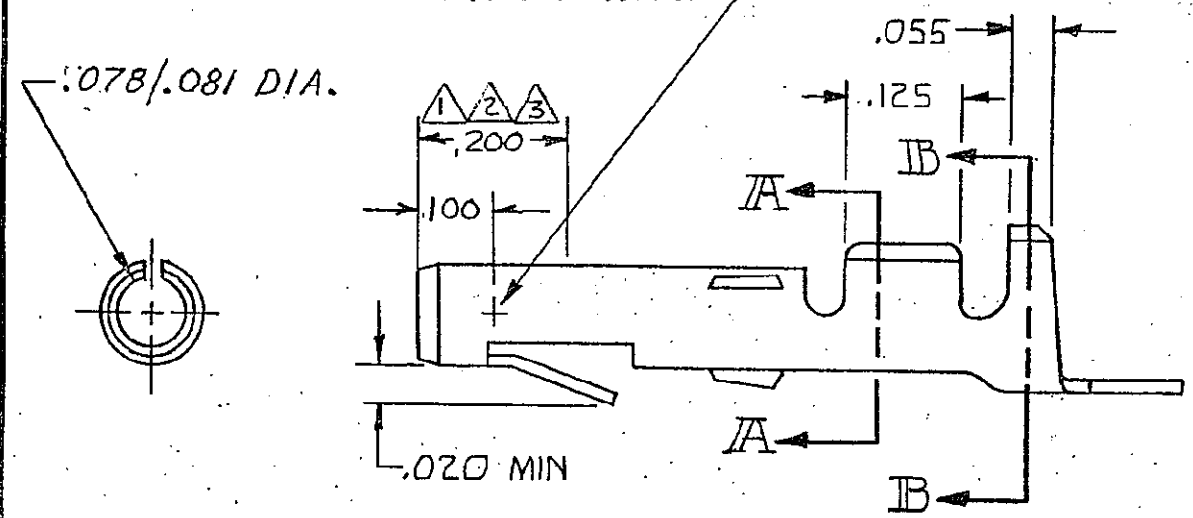

SECTION A-A SECTION B-B

- ① NICKEL ON ENTIRE TERMINAL WITH .000030 GOLD OVER INSIDE OF MATING AREA AND WIRE BARREL.
- ② GOLD FLASH OVER NICKEL ON ENTIRE TERMINAL WITH .000030 GOLD OVER MATING AREA.
- ③ NICKEL ON ENTIRE TERMINAL WITH .000030 GOLD OVER INSIDE OF MATING AREA.

APPLICATOR TYPE	FINISH	MATERIAL	PART NO
MINI	GOLD	.012 BRASS	61314-7
	GOLD	PH. BRZ.	-6
	GOLD	BRASS	-5
	PRE-TIN	PH. BRZ	-4
	—	PH. BRZ.	-3
	—	BRASS	-2
MINI	PRE-TIN	.012 BRASS	61314-1

UNLESS OTHERWISE SPECIFIED DIMENSIONS ARE IN INCHES. TOLERANCES ON: DECIMALS ±.015 ANGLES ±	CONTRACT NO	AMP INCORPORATED Harrisburg, Pa.	
	DR M. FEHER 11-30-79	NAME SOCKET, COMMERCIAL MATE-N-LOK™	
MATERIAL SEE TABLE	CHK D.S. Heide 12/11/79	SIZE B	CODE IDENT NO 00779
FINISH SEE TABLE	APPD D. DeLoach 12/12/79	DRAWING NO 61314	SCALE 5-1
	WIRE RANGE 24-18 AWG.	SHEET 1 OF 1	
	INSULATION DIA .100 MAX	CUSTOMER DRAWING	